

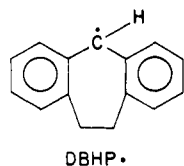
# Photophysics and Photochemistry of Arylmethyl Radicals in Liquids<sup>†</sup>

A. Bromberg, K. H. Schmidt, and D. Meisel\*

Contribution from the Chemistry Division, Argonne National Laboratory, Argonne, Illinois 60439. Received July 23, 1984

**Abstract:** A series of arylmethyl radicals (including  $\text{Ph}_2\dot{\text{C}}\text{H}$ , 10,11-dihydro-5*H*-dibenzo[*a,d*]cyclohepten-5-yl (=DBHP),  $\text{Ph}_2\dot{\text{C}}\text{CH}_3$ ,  $\text{Ph}_2\dot{\text{C}}\text{-c-Pr}$ , and  $\text{Ph}_3\dot{\text{C}}$ ) have been produced pulse radiolytically in a variety of solvents and then excited with  $\lambda = 347$  nm ruby laser pulses.  $\text{Ph}_2\dot{\text{C}}\text{CH}_3$ ,  $\text{Ph}_2\dot{\text{C}}\text{-c-Pr}$ , and  $\text{Ph}_3\dot{\text{C}}$  undergo a solvent independent monophotonic photochemical reaction with high quantum yield. This reaction is proposed to occur from the first excited doublet state and to yield a fluorenyl-type radical.  $\text{Ph}_2\dot{\text{C}}\text{H}$  and DBHP strongly fluoresce upon relaxation to their ground doublet state. Fluorescence spectra as well as excited doublet-doublet absorption spectra of these radicals have been recorded and their lifetimes and fluorescence quantum yields determined. No photochemistry is observed from the lowest excited state of both of these radicals. The difference in photoreactivity of the two groups of radicals ( $\text{Ph}_2\dot{\text{C}}\text{H}$  and DBHP vs.  $\text{Ph}_2\dot{\text{C}}\text{CH}_3$ ,  $\text{Ph}_2\dot{\text{C}}\text{-c-Pr}$ , and  $\text{Ph}_3\dot{\text{C}}$ ) is rationalized as resulting from the degree of twist of the phenyl groups out of the central molecular plane. A solvent-dependent consecutive biphotonic photochemistry from excited states higher than the lowest excited doublet state is, however, observed for the  $\text{Ph}_2\dot{\text{C}}\text{H}$  and DBHP radicals. A mechanism to rationalize this photochemistry is proposed.

The lack of information on lifetimes and reactivities of excited states of organic-free radicals in liquids at room temperature is quite surprising in view of the arsenal of fast-laser techniques employed by many research groups. Even for the more stable carbanions such information is hardly available.<sup>1,2</sup> Among the free radicals, diphenyl ketyl radicals are a notable exception. Following the observation of Mehnert et al.<sup>3</sup> of fluorescence from  $\text{Ph}_2\dot{\text{C}}\text{OH}^*$  radicals, several studies on the photophysics and photochemistry of these radicals at room temperature have been conducted.<sup>4</sup> However, systematic studies on short-lived radicals in their excited states are nonexistent. We have, therefore, initiated this study on the photophysics and photochemistry of short-lived radicals in liquid solutions. In the present report, we focus our attention on a series of arylmethyl radicals, in particular  $\text{Ph}_2\dot{\text{C}}\text{H}$ ,  $\text{Ph}_2\dot{\text{C}}\text{CH}_3$ ,  $\text{Ph}_2\dot{\text{C}}\text{-c-Pr}$ ,  $\text{Ph}_3\dot{\text{C}}$ , and DBHP radicals. A preliminary account of some of our results has already been communicated.<sup>5</sup>



Background information on the spectroscopy and photophysics of the arylmethyl radicals can be extracted from low-temperature studies on these radicals in solid matrices, from gas-phase studies, and from theoretical calculations. Thus, the prototype benzyl radical,  $\text{Ph}\dot{\text{C}}\text{H}_2$  has been extensively studied at 77 K. Fluorescence quantum yields and lifetimes of benzyl and several substituted benzyl radicals at low temperature have been measured and the energy levels of the doublet manifold calculated.<sup>6-11</sup> The first excited doublet state of this family of radicals is relatively long-lived at 77 K (200–1500 ns). The long radiative lifetime is commonly attributed to the low oscillator strength of the symmetry allowed  $^2A_2 \leftarrow ^2B_2$  transition, while the long nonradiative lifetime results from the large energy gap between these two transitions (2.7 eV for  $\text{Ph}\dot{\text{C}}\text{H}_2$ , 2.4 eV for the other radicals presently studied). The latter process has been shown to be primarily dominated by coupling to C–H vibrational modes. Nevertheless, in spite of the detailed information available on the photophysics of these radicals in rigid matrices at low temperature, their behavior in liquids at ambient temperatures could conceivably be quite different. Rotational and vibrational modes, frozen at the lower temperatures, relief from lattice site, and counter ion (or counter radical if

produced photochemically) effects as well as translational diffusion might all contribute to different behavior at the higher temperatures. This, indeed, was found to be the case for some of the radicals studied.

In spite of the obvious structural similarities between all the radicals studied here (e.g., compare  $\text{Ph}_2\dot{\text{C}}\text{H}$  with  $\text{Ph}_2\dot{\text{C}}\text{CH}_3$ ), their photochemical reactivities were found to depend strongly on their detailed structure. While  $\text{Ph}_2\dot{\text{C}}\text{H}$  and DBHP radicals undergo only photophysical decay processes from their lowest excited doublet state, the other three radicals were found to completely photolyze upon excitation to this state at room temperature and in a variety of solvents. Details of both the photophysical and photochemical processes as well as some properties of the excited states are described in this report. A rational for the difference

- (1) (a) Vander Donckt, E.; Nasielski, J.; Thiry, P. *Chem. Commun.* **1969**, 1249. (b) Burley, J. W.; Young, R. N. *Chem. Commun.* **1970**, 1649. (c) Vos, H. W.; Blom, H. H.; Velthorst, N. H.; MacLean, C. *J. Chem. Soc., Perkin Trans. 2* **1972**, 635. (d) Vos, H. W.; MacLean, C.; Velthorst, N. H. *J. Chem. Soc., Faraday Trans. 2* **1976**, 72, 63. (e) Plodinec, J.; Hogen-Esch, T. E. *J. Am. Chem. Soc.* **1974**, 96, 5262; **1978**, 100, 7633.
- (2) Eriksen, J.; Lund, H.; Nyvad, A. *Acta Chem. Scand., Ser. B* **1983**, 37, 459.
- (3) Mehnert, R.; Brede, O.; Helmstreit, W. *Z. Chem.* **1975**, 15, 448.
- (4) (a) Razi Naqvi, K.; Wild, U. P. *Chem. Phys. Lett.* **1976**, 41, 570. (b) Razi Naqvi, K.; Steark, H.; Gillbro, T. *Chem. Phys. Lett.* **1977**, 49, 160. (c) Steark, H.; Razi Naqvi, K. *Chem. Phys. Lett.* **1977**, 50, 386. (d) Thurnauer, M. C.; Meisel, D. *Chem. Phys. Lett.* **1982**, 92, 343. (e) Baumann, H.; Schumacher, K. P.; Timpe, H. J.; Rehak, V. *Chem. Phys. Lett.* **1982**, 89, 315. (f) Baumann, H.; Merckel, C.; Timpe, H. J.; Graness, A.; Kleinschmidt, J.; Gould, I. R.; Turro, N. J. *Chem. Phys. Lett.* **1984**, 103, 497.
- (5) Bromberg, A.; Schmidt, K. H.; Meisel, D. *J. Am. Chem. Soc.* **1984**, 106, 3056.
- (6) (a) Longuet-Higgins, H. C.; Pople, J. A. *Proc. Phys. Soc.* **1955**, 68, 591. (b) Kruglyak, Y. A.; Mozdor, E. V. *Theoret. Chim. Acta* **1969**, 15, 365; **1969**, 15, 374. (c) Chang, H. M.; Jaffe, H. H.; Masamanidis, C. A. *J. Phys. Chem.* **1975**, 79, 1118. (d) Cossart-Magos, C.; Leach, S. J. *Chem. Phys.* **1972**, 56, 1534; **1976**, 64, 4006.
- (7) (a) Porter, G.; Strachan, E. *Spectrochim. Acta* **1958**, 12, 299. (b) Porter, G.; Ward, B. J. *Chim. Phys. Phys.-Chim. Biol.* **1964**, 61, 1517.
- (8) (a) Friedrich, D. M.; Albrecht, A. C. *J. Chem. Phys.* **1973**, 58, 4766. (b) Bromberg, A.; Friedrich, D. M.; Albrecht, A. C. *Chem. Phys.* **1974**, 6, 353. (c) Friedrich, D. M.; Albrecht, A. C. *Chem. Phys.* **1974**, 6, 366.
- (9) (a) Laposa, J. D.; Morrison, V. *Chem. Phys. Lett.* **1974**, 28, 270. (b) Branciard-Larcher, C.; Migirdicyan, E.; Baudet, J. *Chem. Phys.* **1973**, 2, 95.
- (10) (a) Okamura, T.; Obi, K.; Tanaka, I. *Chem. Phys. Lett.* **1973**, 20, 90. (b) *Chem. Phys. Lett.* **1974**, 24, 218. (c) Okamura, T.; Tanaka, I. *J. Phys. Chem.* **1975**, 79, 2728. (d) Hiratsuka, H.; Okamura, T.; Tanaka, I.; Tanizaki, Y. *J. Phys. Chem.* **1980**, 84, 285. (e) Kanamaru, N.; Nagakura, S. *Bull. Chem. Soc. Jpn.* **1970**, 43, 3443. (f) Ono, Y.; Ikeshoji, T.; Mizuno, T. *Chem. Phys. Lett.* **1975**, 34, 451.
- (11) (a) Izumida, T.; Tanabe, Y.; Ichikawa, T.; Yoshida, H. *Bull. Chem. Soc. Jpn.* **1979**, 52, 235. (b) Favaro, G. *Spectrochim. Acta, Part A* **1970**, 26A, 2327.

<sup>†</sup> Work performed under the auspices of the Office of Basic Energy Sciences, Division of Chemical Science, US-DOE under Contract W-31-109-ENG-38.

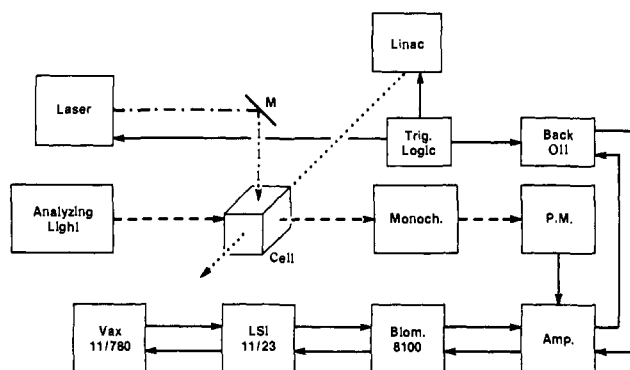
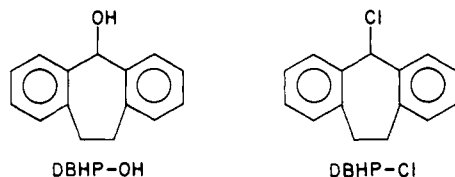


Figure 1. Schematic presentation of the pulse radiolysis/laser flash photolysis system.

in the photochemical reactivity of these two groups is proposed to correlate with the radicals geometry. Another significant observation reported below is a photochemical reaction resulting from the absorption of a second photon by those radicals whose lowest excited state is photochemically stable (i.e.,  $\text{Ph}_2\dot{\text{C}}\text{H}$  and DBHP $\cdot$ ). This consecutive biphotonic process is proposed below to result in a homolytic bond scission to form a carbene and a radical moiety. It is, however, recognized here that at the present level of knowledge on radical photochemistry, any mechanistic discussion is basically confined to the phenomenological level.

### Experimental Section

**Materials.** The following chlorides and carbinols were purified: diphenylmethyl chloride ( $\text{Ph}_2\text{CHCl}$ ) vacuum distilled; diphenylmethanol ( $\text{Ph}_2\text{CHOH}$ ) and 1,1-diphenylethanol, ( $\text{Ph}_2\text{C}(\text{CH}_3)\text{OH}$ ) recrystallized from *n*-heptane; triphenylmethyl chloride ( $\text{Ph}_3\text{CCl}$ ) and triphenylmethanol ( $\text{Ph}_3\text{COH}$ ) recrystallized from isooctane and benzene, respectively; and 10,11-dihydro-5*H*-dibenzo[*a,d*]cyclohepten-5-ol (dibenzo-suberol denoted DBHP-OH) and its chloride analogue (DBHP-Cl), both recrystallized from a 10% ether/*n*-heptane mixture. Cyclohexane



(CHX) was passed through an alumina column and water was triply distilled. All other materials were of the highest purity commercially available and were used without further purification.

**Instrumentation.** A block diagram of the pulse radiolysis/laser flash-photolysis arrangement is shown in Figure 1. The pulse radiolysis system consists of the pulsed linac electron source and the spectrophotometric detection system. The latter includes a pulsed xenon lamp, a monochromator, and a photomultiplier shielded against electromagnetic fields and radiation. Further details of the pulse radiolysis setup have been previously described.<sup>12</sup> The 1-cm cylindrical silica irradiation cell has been modified to incorporate a flat window on its upper side to admit the light beam from a frequency-doubled ruby laser (Korad, Q-switched, KDP crystal,  $\lambda = 347$  nm, ca. 10-ns pulse width).

The laser covers an oval area about  $10 \times 15$  mm on the cell upper window. The analyzing light beam is collimated to a 1-cm diameter on the flat side window of the cell. The linac beam is collimated to a 1 cm square cross section perpendicular to both the laser and analyzing light beams. The laser pulse has a variable delay relative to the linac pulse. In this study we chose a  $\sim 4$ - $\mu\text{s}$  delay. The linac pulse used was of 40-ns width, and the beam energy was ca. 15 MeV. The xenon lamp pulser is triggered at an appropriate time before the linac pulse.

The photomultiplier contains a preamplifier in its shielded housing to reduce noise pickup. A back-off circuit keeps the base line close to zero during the lamp pulse. The output signal is digitized on a Biomation 8100 transient recorder and stored in a LSI 11/23 minicomputer. At the end of a series of experiments, the data are transferred to a central VAX 11/780 computer for processing and plotting.

**Actinometry and Quantum Yields.** Two actinometer solutions, both based on the tris(2,2'-bipyridine)ruthenium(II) sensitizer, were used in

this study. An aqueous solution of  $5 \times 10^{-5}$  M  $\text{Ru}(\text{bpy})_3\text{Cl}_2$  was used as the actinometer for fluorescence quantum yield, assuming its own fluorescence quantum yield to be  $\Phi_{\text{fl}}^{\text{Ru}} = 0.042$ .<sup>13</sup> Fluorescence spectra of this actinometer in the pulse radiolysis/laser flash photolysis setup were recorded point by point, and the integrated area of these spectra were used as a reference to calculate the quantum yields of fluorescence of the radicals. Correction by comparing these spectra with the fluorescence spectrum of the same  $\text{Ru}(\text{bpy})_3^{2+}$  solution recorded on a fluorescence spectrometer equipped with a corrected spectrum unit had little effect on the results. However, since the fluorescence spectra from the radicals do not completely overlap with that of the actinometer, a small error may be introduced due to variations of detector sensitivity with wavelength. The amount of excitation light absorbed by the actinometer solutions was measured on a Varian 219 spectrophotometer prior to the irradiation experiments.

For estimates of the number of incident laser photons necessary to calculate quantum yields of photochemical products at low laser intensities, aqueous solutions containing  $5 \times 10^{-5}$  M  $\text{Ru}(\text{bpy})_3^{2+}$ ,  $2 \times 10^{-2}$  M methyl viologen, ( $\text{MV}^{2+}$ ), and 1% EtOH were used as actinometers. Quantum yield for production of  $\text{MV}^+$ ,  $\Phi_{\text{ph}} = 0.25$ , and  $\epsilon_{600} = 1.2 \times 10^4$   $\text{M}^{-1} \text{cm}^{-1}$  were assumed<sup>14</sup> and corrected for limited quenching (92%) of the  $\text{Ru}(\text{bpy})_3^{2+}$  excited state. For most experiments in this study, this actinometer yields  $3.5 \times 10^{-5}$  einsteins/pulse with less than 15% day-to-day variation. In experiments in which dependence on laser intensity was studied, the intensity was reduced by a series of neutral density filters, the absorption of which was measured. At high laser intensities, the concentration of excited states could be estimated from the bleaching of the absorption of the ground-state radicals and by assuming that the excited states do not absorb at the same wavelength (see below). Once the population of excited states is known, fluorescence quantum yields could be calculated.  $\text{MV}^{2+}$  aqueous solutions containing 1% EtOH were also used as dosimeters for the linac pulse. Assuming  $G = 6.2$  molecules/100 eV for  $\text{MV}^+$ ,<sup>15</sup> this yields 11 krad per 40 ns linac pulse.

**Extinction Coefficients Determination.** Extinction coefficients of the radicals in their ground state in the various solvents were determined relative to that of  $\text{Ph}_3\text{C}\cdot$ . For the latter, we take  $\epsilon_{338} = 3.6 \times 10^4$   $\text{M}^{-1} \text{cm}^{-1}$ ,<sup>16</sup> independent of the solvent, and assume that with increasing concentration the same limiting yield of dissociative electron capture was obtained for all compounds studied. The extinction coefficients of the parent molecules are negligible in the whole spectral range ( $\lambda > 280$  nm). For the species produced by the laser flash (excited states or photochemical products), we assume that the contribution of these products to the total absorption at the wavelength where the absorption by the ground state of the radical is at its maximum could be neglected. This assumption is justified in the Results section below. With this assumption, one can also estimate the fraction of ground-state radicals which are converted (excited or reacted photochemically) by the laser flash. The complete spectrum could then be corrected for depletion of this fraction of ground-state radicals. If the absorption of the product species does contribute to the absorption at  $\lambda_{\text{max}}$  of the ground state, the estimates for the fraction of ground states bleached will be a lower limit for this fraction.

**Procedure.** Solutions of the corresponding chloride or carbinol were freshly prepared prior to irradiation. Degassing, using the syringe technique, with ultrapure argon for ca. 10 min reduced the level of dissolved oxygen concentration to approximately micromolar. For each of the radicals in acetonitrile (AcN) solutions, saturation with  $\text{N}_2\text{O}$  or  $\text{SF}_6$  as the electron scavenger reduced the yield of the radical to  $< 5\%$  of its yield in the Ar-saturated solution. However, in CHX solutions, these electron scavengers removed only  $\sim 70\%$  of the absorption in the spectral range where the radical is absorbing. We suspect some hole scavenging reaction to produce an oxidation product which absorbs in the same region. Addition of  $\sim 1$  mM EtOH as the hole scavenger to the CHX solutions reduced the absorption in this region, but ethanol in CHX reacts also with the electrons. Thus, the alcohol in CHX efficiently competes with the parent molecules studied and reduces the yield of the radicals of interest. This competition is severe when the carbinols are used as parent molecules since their rate of reaction with the electrons is relatively slow. We, however, prefer to use the carbinols whenever alcohol is present in the solutions in order to avoid the problem of alcoholysis of the chloride. At any rate, none of the observations discussed in this study,

(13) Van Houten, J.; Watts, R. J. *J. Am. Chem. Soc.* **1975**, *97*, 3843; **1976**, *98*, 4853.

(14) Kalyanasundaram, K.; Neumann-Spallart, M. *Chem. Phys. Lett.* **1982**, *88*, 7.

(15) Meisel, D.; Mulac, W. A.; Matheson, M. S. *J. Phys. Chem.* **1981**, *85*, 179.

(16) Taub, I. A.; Harter, D. A.; Sauer, M. C.; Dorfman, L. M. *J. Chem. Phys.* **1964**, *41*, 979.

(12) Gordon, S.; Schmidt, K. H.; Hart, E. J. *J. Phys. Chem.* **1977**, *81*, 104.

Table I. Absorption, Fluorescence, and Photochemical Characteristics of Phenylmethyl Radicals at Room Temperature in AcN

radical	ground state ( $D_0$ ) absorption		excited state ( $D_1$ ) absorption <sup>a</sup>				
	$\lambda$ , nm	$\epsilon$ , $M^{-1} cm^{-1}$	absorption <sup>a</sup>		fluorescence		
	$\lambda$ , nm	$\epsilon$ , $M^{-1} cm^{-1}$	$\lambda$ , nm	$\epsilon$ , $M^{-1} cm^{-1}$	$\lambda_f$ , nm	$\Phi$	$k_0 \times 10^{-6}$ , $s^{-1}$
Ph <sub>2</sub> CH	331	$4.4 \times 10^4$	405	$2.8 \times 10^4$	540	0.29	3.6
	318	$3.1 \times 10^4$	355	$3.3 \times 10^4$	525		
Ph <sub>3</sub> C	338	$3.6 \times 10^4$ <sup>c</sup>	photochem.				
	320	$1.7 \times 10^4$	490	$(1.2 \times 10^4)$		$(1.0)^d$	$(>40)^d$
Ph <sub>2</sub> CCH <sub>3</sub>	331	$2.0 \times 10^4$	photochem.				
	315	$1.3 \times 10^4$	480	$(8.6 \times 10^3)$		$(1.2)^d$	$(>40)^d$
DBHP	333	$2.2 \times 10^4$	430	$2.4 \times 10^4$	560	0.26	3.8
	323	$2.3 \times 10^4$	400	$1.3 \times 10^4$	540		
			360 (photochem. 410) <sup>e</sup>	$2.0 \times 10^4$ $(1.1 \times 10^4)$			

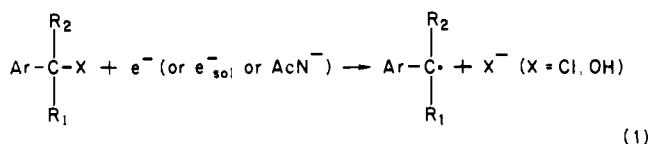
<sup>a</sup> Values in parentheses are for photochemical products. <sup>b</sup> Absorptions in the visible range are too small to observe on the same scale and were not studied. <sup>c</sup> Taken from ref 16. <sup>d</sup> Yield and rate of photochemical reaction. <sup>e</sup> This particular absorption refers to results in AcN only.

which were caused by the laser flash, could be observed in the N<sub>2</sub>O- or SF<sub>6</sub>-saturated solutions.

None of the phenomena described below could be observed (none is to be expected either) when the linac pulse prior to the laser flash was eliminated. Nevertheless, primarily to minimize electrical noise and laser scattered light effects, a run in which only the laser was fired was used as a base line for each run of the linac-laser experiment. This was repeated point by point for each wavelength studied. The experimental points were analyzed by using a nonlinear least-squares fitting routine to obtain the rate law and kinetic parameters.

## Results and Discussion

The arylmethyl radicals were produced by dissociative electron capture through reaction 1. Reaction 1 with the chlorides is faster



than the experimental time resolution at the chloride concentrations used in the pulse radiolysis/flash photolysis experiments. Reaction 1, with the carbinols, is somewhat slower. In AcN we obtain from the linear dependence of observed pseudo-first-order rate constants for the formation of the radical on the carbinol concentration ( $(0.5-5.0) \times 10^{-3} M$ )  $k_1 = 4.2 \times 10^9 M^{-1} s^{-1}$  for Ph<sub>3</sub>COH,  $k_1 = 4.6 \times 10^9 M^{-1} s^{-1}$  for Ph<sub>2</sub>CHOH,  $k_1 = 3.5 \times 10^9 M^{-1} s^{-1}$  for DBHP-OH, and  $k_1 = 1.1 \times 10^9 M^{-1} s^{-1}$  for Ph<sub>2</sub>C(Me)OH. The low value for diphenylethanol is quite surprising. In all the experiments described below, the laser flash hits the sample after more than 99% of reaction 1 is over.

**Photophysics of Ph<sub>2</sub>CH Radicals.** Results of our study on the excitation of the Ph<sub>2</sub>CH radical were summarized in a previous communication<sup>5</sup> and will only briefly be recounted here. Pulse radiolytic production of Ph<sub>2</sub>CH radicals (by dissociative electron capture of the chloride or the carbinol) in AcN was followed by excitation with the frequency-doubled ruby laser. Only the first excited doublet state of the radical ( $k_0 = (3 \pm 0.3) \times 10^6 s^{-1}$ ) could be observed in AcN, and its fluorescence as well as the doublet-doublet absorption spectra were recorded. Some absorption and fluorescence parameters of the first excited state are collected in Table I.

While no photochemistry of the radical could be observed in AcN, we now observe that an appreciable percentage of the excited radicals undergo a photochemical process when excited in ethanol or water. Thus, following excitation of Ph<sub>2</sub>CH radicals in ethanol (EtOH), only 55% of the excited radicals relaxed back to the ground state, while 45% of them yield "permanent" (on the radicals' lifetime scale) products. In water, a slightly larger percentage (55%) of the excited radicals undergo the photochemical process. A similar yield of the photochemical process is observed in D<sub>2</sub>O (50%). Close examination of the absorption of the photochemical product obtained either in H<sub>2</sub>O or EtOH reveals no absorption band in the vicinity of  $\lambda \sim 490$  nm. This spectral range is characteristic of a photochemical product obtained upon excitation of Ph<sub>3</sub>C $\cdot$  (see below), and we, therefore, propose

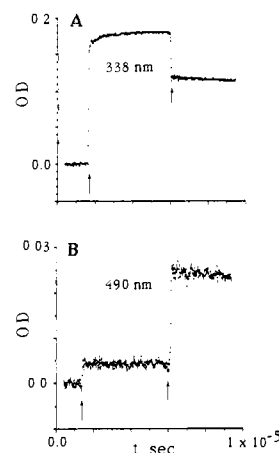


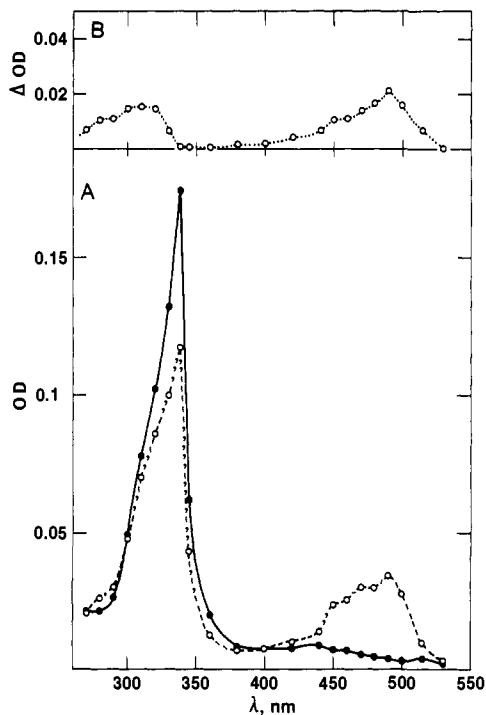
Figure 2. Laser flash photolysis of triphenylmethyl radicals in ethanol. A Ph<sub>3</sub>COH Ar-saturated solution ( $5 \times 10^{-3} M$ ) in EtOH is used to produce pulse-radiolytically  $5 \times 10^{-6} M$  Ph<sub>3</sub>C $\cdot$  radicals. Linac pulse and laser flash are indicated by the arrows. Wavelengths are indicated.

that a different photochemical process, involving the solvent, takes place upon excitation of Ph<sub>2</sub>CH radicals.

The lifetime of the excited state (estimated from decay of fluorescence or decay of doublet-doublet absorption) is the same, within experimental error, in EtOH, H<sub>2</sub>O, and D<sub>2</sub>O as in AcN. Furthermore, the quantum yield for fluorescence in all four solvents was measured to be  $0.30 \pm 0.03$ . The lack of dependence of the quantum yield for fluorescence on the solvent, regardless of whether photochemistry is observed or not, leads us to believe that the primary photochemical process is common to all solvents studied, i.e., is a unimolecular process of the excited radical. The solvent, however, is involved in determining the fate of the products of the primary process on the very short time scales. The constant lifetime of the first excited doublet state in the various solvents also indicates that the primary photochemical process originates from a state higher than the lowest excited state.

We also studied the yield of fluorescence and photochemical products as a function of laser light intensity. While the accuracy of the photochemical yields does not allow a definite conclusion, the fluorescence quantum yield approaches a saturation level at higher laser light intensities. We, therefore, suggest that the photochemical process arises from an absorption of a second photon by the first excited doublet state, i.e., a consecutive bi-photon process. A similar process is observed following excitation of DBHP $\cdot$  radicals and will be discussed in more detail in conjunction with the latter radical.

**Photochemistry of Ph<sub>3</sub>C $\cdot$  Radicals.** Triphenylmethyl chloride or triphenylmethanol have been used as precursors for Ph<sub>3</sub>C $\cdot$  radicals which were then photolyzed with the frequency-doubled ruby laser. The time dependence of the absorbances obtained at two wavelengths is shown in Figure 2. Only "permanent" bleaching or "permanent" absorption formation (on the time scale of the radical lifetime,  $\sim 100 \mu s$ ) could be observed following the

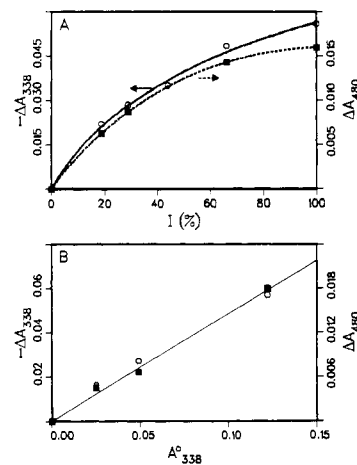


**Figure 3.** (A) Absorption spectrum of  $\text{Ph}_3\text{C}\cdot$  radicals in EtOH before (solid line) and after (dashed spectrum) the laser flash. (B) Absorption spectrum of the photolysis product of  $\text{Ph}_3\text{C}\cdot$  calculated assuming no absorption of the products at the absorption maximum (338 nm) of the radical (see text). Experimental conditions as in Figure 2.

laser flash in the spectral range of 270–550 nm. No fluorescence from an excited state of this radical could be observed in any of the solvents studied ( $\text{CH}_3\text{CN}$ , CHX, or EtOH). The absorption spectrum of the  $\text{Ph}_3\text{C}\cdot$  radical is shown in Figure 3. The spectrum following the laser flash, i.e., mixture of radical and photolysis products, is also shown in Figure 3 as the dashed spectrum. Assuming that the products absorb only negligibly at  $\lambda_{\text{max}} = 338$  nm of the radical, one can extract the absorption spectrum of the photolysis products from the two spectra in Figure 3A. In the particular case shown in Figure 3A, 37% of the absorbance at 338 nm is bleached following the laser flash. Assuming the same percentage of photolysis across the whole spectral range yields the products spectrum shown in Figure 3B. This assumption seems reasonable in view of the sharpness of the absorption band of the  $\text{Ph}_3\text{C}\cdot$  radical in the vicinity of its peak. Further justification for this assumption is obtained from calculating the quantum yield for bleaching of the  $\text{Ph}_3\text{C}\cdot$  radicals. Using the  $\text{Ru}(\text{bpy})_3^{2+}/\text{MV}^{2+}$  actinometry system (see Experimental Section) and making the same assumption as above, we obtain  $\Phi = 1.05 \pm 0.1$  for bleaching of the radical. Any appreciable absorption by the photolysis products at 338 nm would increase the calculated quantum yield beyond the limit of 1.0. Taking  $\epsilon_{338} = 3.6 \times 10^4 \text{ M}^{-1} \text{ cm}^{-1}$  for  $\text{Ph}_3\text{C}\cdot$  and using the same assumptions, we obtain  $\epsilon_{480} = (1.5 \pm 0.1) \times 10^4 \text{ M}^{-1} \text{ cm}^{-1}$  for the photolysis product at its absorption maximum.

Very similar spectra were obtained following the laser flash photolysis of  $\text{Ph}_3\text{C}\cdot$  radical in a variety of solvents. These include CHX,  $\text{CH}_3\text{CN}$ , EtOH, and  $10^{-3} \text{ M}$  EtOH (as hole scavenger) in CHX. Characteristic of the absorption spectra of the photolysis products in all these various solvents is the strong absorption peak at 480–490 nm. Furthermore, calculation of the extinction coefficient of the product, as described above, yields similar values in these solvents, although the radiolytic yield of  $\text{Ph}_3\text{C}\cdot$  varies considerably in these various solvents. These results seem to exclude the possible participation of the solvent in the photochemical reaction. However, before proceeding to further discuss the nature of the photochemical product, the question of mono- vs. multiphotonic processes should be addressed.

Since the number of incident photons in the laser flash exceeds substantially the number of absorbing radicals, the possibility of

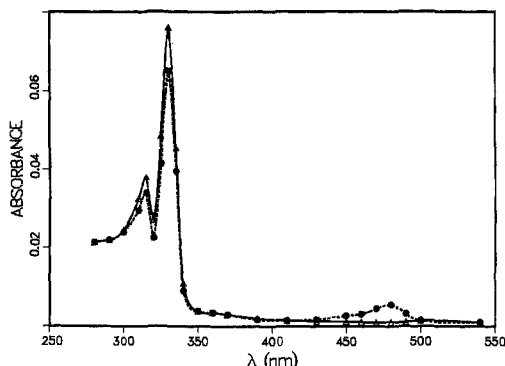


**Figure 4.** Yield of photolysis products following laser flash photolysis of  $\text{Ph}_3\text{C}\cdot$  radicals (A) as a function of laser intensity (40-ns linac pulse) and (B) as a function of linac dose (represented as absorbance of radiolytically produced radicals): (O) measured as bleaching at  $\lambda = 338$  nm, (●) measured from absorption of products at  $\lambda = 480$  nm;  $10^{-3} \text{ M}$   $\text{Ph}_3\text{CCl}$  in AcN.

a biphotonic process cannot be ignored. The yield of photochemical products was studied as a function of laser intensity and of radiolytic dose. Results are summarized in Figure 4. The dependence on laser intensity shows saturation of photochemical yield at higher laser intensities. This is presumably a result of depletion of radicals due to the laser-induced photochemical reaction. At any rate, no indication of a biphotonic process can be deduced from these results. As expected, the photochemical yield is linear with the amount of radicals produced by the linac pulse (Figure 4B). Note that the percentage of excitation light (347 nm) absorbed by the radicals is quite small (<9%) and, thus, should increase nearly linearly with the concentration of the radiolytically produced radicals.

Positive identification of the photochemical product turns out to be difficult in view of the variety of radiolytic and photolytic product mixtures. Nevertheless, some routes could be excluded and others could be proposed. As mentioned above, the lack of solvent effects excludes solvent participation in the photochemical reaction. On the other hand, since the formation of the photochemical product is faster than our time resolution, any other bimolecular reaction can also be excluded. The reaction producing this product is, therefore, a unimolecular reaction. Photoionization can also be excluded since any photoproduced electron in the solvents studied would rapidly reform the  $\text{Ph}_3\text{C}\cdot$  radical and no bleaching would be observed. The possibility of homolytic bond scission to form a phenyl radical and a diphenylcarbene can also be rejected since the carbene would rapidly react with EtOH, while we observe similar products in EtOH, CHX, and AcN. We also consider the possibility of intersystem crossing to the quartet manifold to yield a long-lived quartet state rather unlikely. For the photochemical product discussed above to be the lowest quartet state, its lifetime has to be longer than  $\sim 100 \mu\text{s}$ . This seems too long for the quartet state of triphenylmethyl radicals (or diphenylethyl ( $\text{Ph}_2\text{CCH}_2$ ) radicals; see below). Although the energy level of the quartet state of these radicals has not yet been determined, the energy levels of the doublet manifold of diphenylmethyl have been calculated.<sup>10e</sup> According to these calculations, the density of states above the first excited doublet state provides a gap of  $<0.5 \text{ eV}$ . Since the lowest quartet state has to be situated above the first excited doublet, this  $<0.5 \text{ eV}$  is also the largest gap for intersystem crossing from the quartet to the doublet manifold. According to Siebrand's correlation of the energy gap with the lifetime for radiationless transitions of intersystem crossing,<sup>17</sup> such a small gap would result in extremely short lifetimes. It should also be noted that we fail to observe any long-lived delayed emission in this system. All these con-

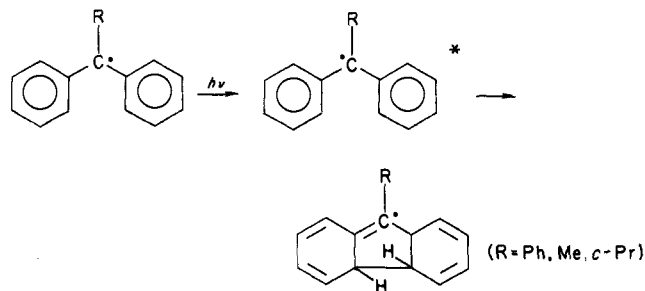
(17) Siebrand, W. *J. Chem. Phys.* **1966**, *44*, 4055; **1967**, *47*, 2411.



**Figure 5.** Absorption spectrum of pulse-radiolytically produced  $\text{Ph}_2\dot{\text{C}}\text{CH}_3$  radicals before ( $\Delta$ , solid spectrum) and immediately following ( $\bullet$ , dashed spectrum) the laser flash:  $10^{-2}$  M  $\text{Ph}_2\text{C}(\text{CH}_3)\text{OH}$  in Ar-saturated AcN solution.

siderations, although not definitive, lead us to believe that the observed bleaching of  $\text{Ph}_3\dot{\text{C}}$  radicals cannot be attributed to the formation of the quartet state itself.

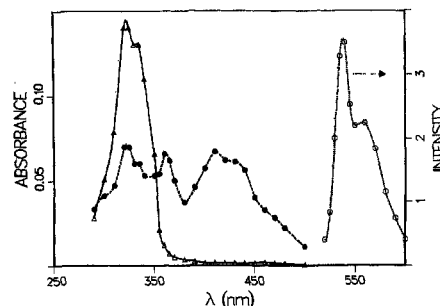
The remaining available route to the formation of the photo-product seems, therefore, to be a unimolecular rearrangement of the radical. A plausible reaction seems to be photocyclization according to



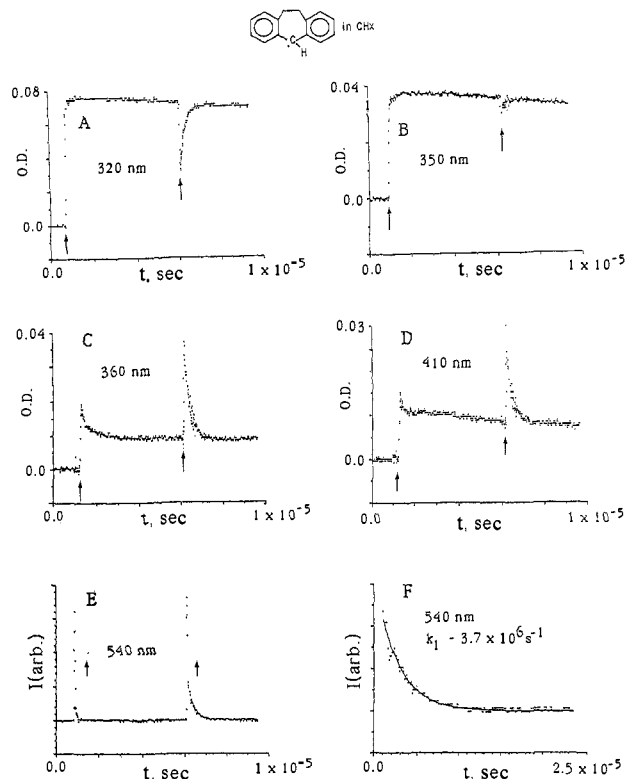
The similar photocyclization of diphenylamines and triphenylamines as well as that of the closely related *cis*-stilbenes is well documented.<sup>18</sup>

**Photolysis of  $\text{Ph}_2\dot{\text{C}}\text{CH}_3$  and  $\text{Ph}_2\dot{\text{C}}\text{-}c\text{-Pr}$  Radicals.** Diphenylethyl radicals were produced pulse-radiolytically from 1,1-diphenylethanol in acetonitrile and were then flash-photolyzed. Similar results to those described above for  $\text{Ph}_3\dot{\text{C}}$  radicals were obtained. No fluorescence from this radical could be observed in the spectral range of 500–600 nm. The spectrum of the radical before the laser flash and immediately following the flash is shown in Figure 5. Except for the more pronounced shoulder at  $\lambda = 320$  nm, the spectrum of the ground state is similar to that of  $\text{Ph}_2\dot{\text{C}}\text{H}$  radicals. On the other hand, the absorption spectrum of  $\text{Ph}_2\dot{\text{C}}\text{CH}_3$  is blue-shifted as compared to that of  $\text{Ph}_3\dot{\text{C}}$  (from  $\lambda_{\text{max}} = 338$  to 331 nm). This blue shift and the narrower absorption band of the  $\text{Ph}_2\dot{\text{C}}\text{CH}_3$  radical renders the fraction of the photolyzing laser light which is absorbed by the radical rather small (0.013). Nevertheless, using the procedure outlined above and with similar assumptions, we obtain  $\Phi = 1.2 \pm 0.2$  for photobleaching of the radical. From the signal-to-noise ratio, we estimate the quantum yield for fluorescence of  $\text{Ph}_2\dot{\text{C}}\text{CH}_3$  to be at least a factor of 5 smaller than that of  $\text{Ph}_2\dot{\text{C}}\text{H}$ . As is clear from Figure 5, a product with an absorption spectrum peaking at 480 nm is obtained following the laser flash. We conclude that the photochemistry of  $\text{Ph}_3\dot{\text{C}}$  radicals follows a similar route to that of the  $\text{Ph}_3\dot{\text{C}}$  radicals.

We also briefly studied the flash photolysis of the cyclopropyldiphenylmethyl radical ( $\text{Ph}_2\dot{\text{C}}\text{-}c\text{-Pr}$ ) produced from the corresponding carbinol by dissociative electron capture. Spectra similar to those of the  $\text{Ph}_2\dot{\text{C}}\text{CH}_3$  radical before and after the laser flash were obtained. From these results we deduce that the cyclopropyldiphenylmethyl radicals follow photochemical reactions similar to the  $\text{Ph}_2\dot{\text{C}}\text{CH}_3$  and  $\text{Ph}_3\dot{\text{C}}$  radicals.



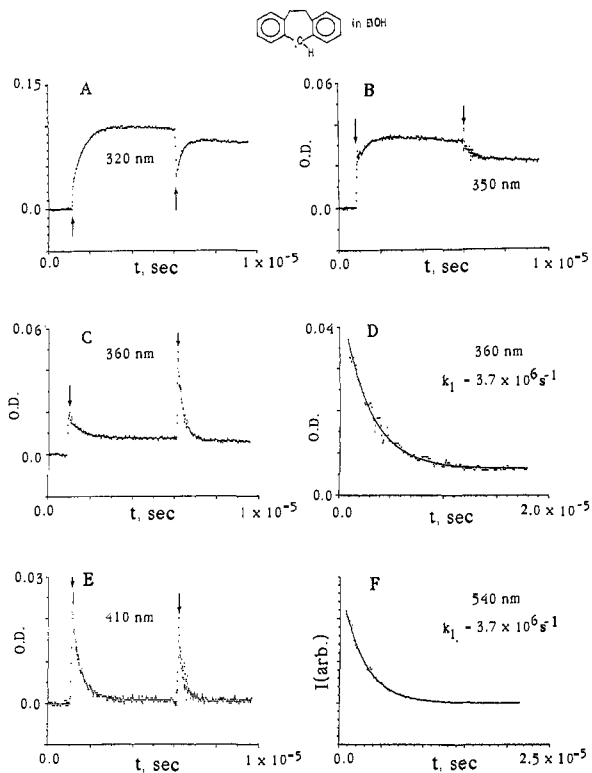
**Figure 6.** Absorption spectrum of DBHP· radicals in AcN before ( $\Delta$ , solid spectrum) and immediately following the laser flash ( $\bullet$ , dashed spectrum). Dotted spectrum is fluorescence spectrum of the radical;  $1 \times 10^{-3}$  M DBPH-Cl deaerated solution.



**Figure 7.** Kinetics of excited DBHP· radicals, produced by pulse radiolysis of a  $2 \times 10^{-3}$  M solution of the corresponding carbinol in CHX: (A)  $\lambda = 320$  nm, bleaching of the ground state; (B)  $\lambda = 350$  nm, nearly isosbestic point of the ground and excited states; (C,D)  $\lambda = 360, 410$  nm, absorption maxima of the first excited doublet; (E) fluorescence at  $\lambda = 540$  nm; and (F) least-squares fit (solid curve) to a single exponential decay of the fluorescence at  $\lambda = 540$  nm.

**Photophysics and Photochemistry of DBHP· Radicals.** In an effort to study a benzyl-type radical for which photocyclization is unlikely, we investigated the effect of the laser excitation on DBHP· radicals in CHX, alcohols, and AcN. The absorption spectrum of the radical in AcN solutions is shown in Figure 6. The absorption peaks in the UV region are slightly red-shifted ( $\lambda = 323$  and 333 nm) as compared to the  $\text{Ph}_2\dot{\text{C}}\text{H}$  radicals, but the bands are somewhat broader. Thus, a larger fraction of the excitation light is absorbed by the radical (16%) which allows a somewhat more detailed study of the photophysics and photochemistry of this radical. The vibrationally structured fluorescence spectrum of this radical (Figure 6, dotted spectrum) is also shifted ( $\lambda_{\text{max}} = 540$  nm) as compared to the fluorescence of  $\text{Ph}_2\dot{\text{C}}\text{H}$ . This red shift would result if a higher degree of coplanarity of the two phenyl groups is caused by the bridging ethylene moiety.

The photophysics and photochemistry of the DBHP· radicals are strongly solvent dependent. In CHX, only the first excited doublet could be observed. The kinetic behavior in this solvent at several representative wavelengths is shown in Figure 7. At



**Figure 8.** Kinetics of the excited DBHP radicals in EtOH solutions. Radicals were produced by pulse radiolysis of a  $2 \times 10^{-3}$  M solution of the corresponding carbinol: (A–C,E) absorption mode detected at the wavelength indicated; (D,F) least-squares fit (solid curves) to a single exponential decay of the absorption at  $\lambda = 360$  nm (D) and fluorescence at  $\lambda = 540$  nm (F). Note the incomplete recovery of ground state at  $\lambda = 320$  nm and “slow” bleaching at  $\lambda = 350$  nm.

$\lambda = 320$  nm, close to the absorption maximum of ground-state DBHP, strong bleaching can be observed (Figure 7A). At  $\lambda = 360$  nm and 410 nm, the excited state absorbs significantly more strongly than the ground state (Figure 7C,D), while at  $\lambda = 350$  nm both states seem to have similar extinction coefficients (Figure 7B). At 540 nm, the fluorescence from the first excited doublet is seen to decay in a single exponential mode (Figure 7E,F). In fact, in all three modes—recovery of the ground-state absorption, decay of the absorption of the excited state, or decay of the fluorescence—we obtain the same rate constant,  $k_0 = (3.8 \pm 0.3) \times 10^6 \text{ s}^{-1}$ . The decay rate constant and the doublet–doublet absorption maxima at 360 and 410 nm are essentially the same as for the  $\text{Ph}_2\dot{\text{C}}\text{H}$  radicals. We, thus, conclude that in CHX the first excited doublet (or any higher excited state that might be populated by the 347-nm excitation light) either undergoes no photochemical reaction or, if any photochemical reaction occurs, the ground state of the radical is rapidly regenerated.

Photochemistry of the excited DBHP radicals is, however, observed in alcoholic solutions. The kinetic behavior following the excitation pulse in EtOH solutions is shown in Figure 8. Contrary to the observation in CHX, an incomplete recovery of the ground-state absorption is observed at  $\lambda = 320$  nm (Figure 8A). At  $\lambda = 350$  nm, a relatively slow bleaching (Figure 8B) seems to parallel the fluorescence decay (Figure 8F) or the decay of the excited-state absorption at  $\lambda = 360$  and 410 nm (Figure 8C–E), following the laser excitation. If, indeed, as might be inferred from Figure 8B,  $\lambda = 350$  nm is an isosbestic point for the ground and excited states, the slow bleaching will indicate a photochemical reaction from the first excited doublet. Since we observe no indication for such a reaction from the first excited doublet state in any other experiment, some effort has been devoted to resolve this point. The arguments below lead us to believe that such is not the case and that the relaxed lowest excited doublet state is not photochemically active.

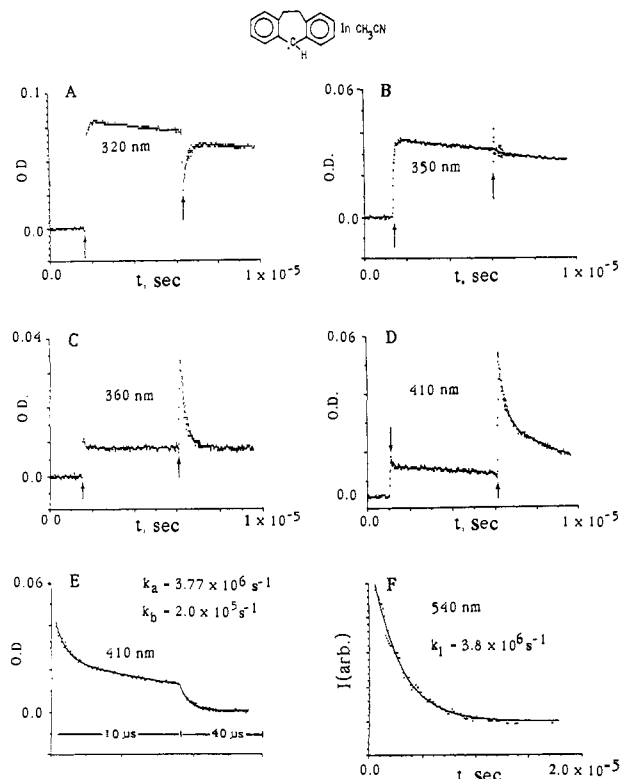
The lifetime of the lowest excited state in EtOH (as well as in other alcohols (MeOH, *i*-PrOH, *t*-BuOH)) is practically the

same as it is in the CHX and AcN ( $\tau_0 = 265 \pm 30$  ns). It is also the same as the lifetime of excited  $\text{Ph}_2\dot{\text{C}}\text{H}$  in these solvents, including alcohols and water where photochemistry has been observed. In the latter cases, we already conclude that the photochemistry occurs from a state other than the relaxed lowest excited state. The amount of excited DBHP radicals which have reacted can be estimated from the fraction of absorption of the ground state which is unrecovered at the end of the decay of the first excited doublet state at  $\lambda = 320$  nm. This amounts to a fraction of  $0.40 \pm 0.05$  in MeOH and  $0.22 \pm 0.03$  in EtOH, *i*-PrOH, and *t*-BuOH. The corresponding effect on the lowest excited-state lifetime, if the photochemical reactions were occurring from this state, would certainly be larger than our experimental errors. The reasons for the reaction seemingly arising from the first excited doublet state (Figure 8B) is, therefore, an accidental match of the amount of bleached absorption of the ground state, due to both excitation and photochemistry, with the absorption of the lowest excited state. Once this point is realized, no experimental result indicates a reaction from the lowest excited state.

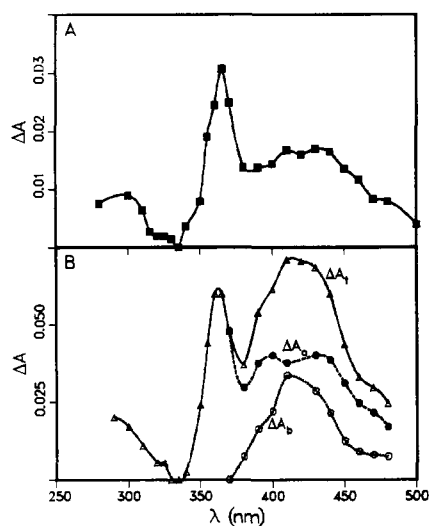
The photochemical reaction in the alcoholic solvents seems to involve the solvent, since no such reaction is observed in CHX. The conventional route for the reaction with the alcohols would be hydrogen abstraction from the  $\alpha$ -hydroxy position. However, the dependence of the yields of the photochemical reaction on the alcohol does not substantiate this suggestion. In particular, the higher yield in MeOH than in *i*-PrOH and the same yields of photochemical reaction obtained in *i*-PrOH and *t*-BuOH indicate that the  $\alpha$ -hydroxy hydrogen is not preferentially abstracted. Also, the high yield for the photochemistry of  $\text{Ph}_2\dot{\text{C}}\text{H}$  in  $\text{H}_2\text{O}$  leads to a similar conclusion. More probably, and in line with the trend of increasing acidity of the alcohol and statistical abundance of OH moieties, the hydroxyl is the site of attack. We, however, find little effect on the quantum yield of photochemical reaction upon deuteration of the hydroxyl group of EtOH. A primary isotope effect would certainly be large enough to be observed above the experimental error of the presently used instrumentation. It is, therefore, quite conceivable that the initial step is addition to the hydroxyl oxygen.

Excitation of DBHP radicals in AcN leads to an even more complex kinetic behavior. As can be seen in Figure 9, the new feature in acetonitrile is the slower decay of the absorption signal that can be observed at  $\lambda = 410$  nm, following the decay of the first excited state (Figure 9D). Using a nonlinear least-squares best fit routine, the decay of the absorption in the range of 370–480 nm fits quite well to a double exponential decay curve. In order to reduce the number of free parameters, the rate of the fast exponential decay in this spectral range was fixed at  $k_a = 3.77 \times 10^6 \text{ s}^{-1}$ , an averaged value obtained from a large number of repetitive measurements of the decay of the fluorescence of the excited state of the radical. Thus, two parameters were obtained from such fits, the rate constant for the slow decay,  $k_b = (4.0 \pm 0.5) \times 10^5 \text{ s}^{-1}$ , and the fraction of the absorption which decays through each of the processes. An example of this procedure is shown in Figure 9E, and the resultant spectra thus obtained are presented in Figure 10B. In the latter figure,  $\Delta A_i$  is the total absorbance change (corrected for ground-state bleaching as described in the Experimental Section) immediately following the laser flash. The fraction of this absorbance which decays by the fast and slow processes and is obtained by the kinetic analysis was used to calculate  $\Delta A_a$  and  $\Delta A_b$ , respectively.

The two processes observed in the range of 370–480 nm could represent either two consecutive processes or two parallel reactions. In the former case,  $\Delta A_i$  will be attributed to the absorption spectrum of the fast decaying species (the first excited doublet state) and  $\Delta A_b$  to its photochemical product. In the latter case  $\Delta A_a$  and  $\Delta A_b$  will be attributed to the shorter and longer lived species, respectively, both of which are present in the solution immediately after the laser flash. Our experimental results indicate that the latter interpretation is the correct one. For comparison purposes, we include in Figure 10A also the spectrum of the excited radical in CHX solutions, where only one species is observed. The similarity of this spectrum to the  $\Delta A_a$  spectrum

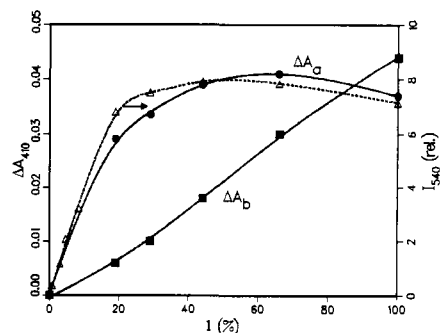


**Figure 9.** Photochemistry of DBHP• radicals in AcN. Experimental conditions as in Figure 8: (A–D) absorption signals at the indicated wavelengths; (E) least-squares fit of the decay of the absorption at  $\lambda = 410$  nm assuming two exponential decays, one of which fixed at  $k_a = 3.77 \times 10^6 \text{ s}^{-1}$  (solid curve); (F) monoexponential decay of fluorescence at  $\lambda = 540$  nm.



**Figure 10.** Absorption spectra of the first excited state of DBHP• radicals in CHX (A) and in AcN (B) with its photolysis products.  $\Delta A_t$  is the total absorbance change (corrected for ground-state bleaching) immediately following the laser flash;  $\Delta A_a$  is the absorbance due to the fast exponential decay, and  $\Delta A_b$  is the fraction due to the slow decay. At  $\lambda < 370$  nm only one process is observed. Experimental conditions as in Figure 8.

and the similar lifetimes of the fast process in both solvents indicate that both species are present in the AcN solution immediately after the laser pulse. One of these species is obviously the first excited doublet state. The longer lived species (with spectrum  $\Delta A_b$  and  $\tau = 2.5 \mu\text{s}$ ) is a photochemical product which results from a reaction of a state other than the first excited doublet and thus competes with internal conversion to the latter. It is realized that this interpretation requires a lower quantum yield for fluorescence of DBHP• radicals in AcN (and in alcohols) as



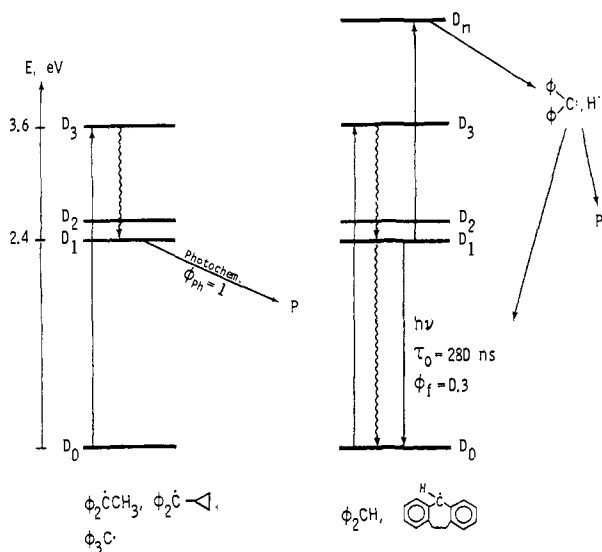
**Figure 11.** Effect of laser light intensity on fluorescence intensity ( $I_{540}$ ) and on absorbance of the lowest excited state ( $\Delta A_a$ , measured at 410 nm) and of the photochemical product ( $\Delta A_b$ , measured at 410 nm) for DBHP• radicals in AcN. Experimental conditions as in Figure 8.

compared to that in CHX. We, however, obtain the same quantum yield for fluorescence in both solvents. The constant values obtained for fluorescence yields and lifetimes in the various solvents as well as the high percentage of ground-state radical ( $\sim 50\%$ ) that are bleached by the laser flash lead us to suspect that a biphotonic process is responsible for the photochemical reaction of DBHP•. This, indeed, is verified by studying the effect of the laser light intensity on the fluorescence intensity and on the amount of photochemical products. Figure 11 summarizes these results in AcN. As can be seen in Figure 11, the fluorescence intensity ( $I_{540}$  in Figure 11) and the absorbance due to the lowest excited doublet state ( $\Delta A_a$ ), measured at 410 nm, changes very little over a wide range of laser intensities presently studied. Similarly, the percentage of the ground state of the radicals which is removed by the laser flash (measured by the percentage bleached at  $\lambda = 330$  nm, not shown in Figure 11) increases from 42% to only 51% in the same saturation range. These results clearly indicate saturation of the population of excited states at relatively low laser intensities. This saturation at  $\sim 50\%$  bleaching results from competitive excitation of ground-state radicals and further excitation of lowest excited doublet state radicals. Note that at the excitation wavelength, the ground and excited states are nearly isosbestic. In accordance with saturation of the lowest excited state, the concentration of the photochemical products can be seen in Figure 11 to increase nearly linearly with increase in laser intensity above a certain intensity. We can, therefore, conclude that the photochemical products result from an absorption of a second photon by the already excited radical. Since in all other solvents presently studied  $\sim 50\%$  of the ground-state radicals are also bleached, we conclude by inference that similar primary photochemical events occur in these solvents as well. The quantum yield for fluorescence in all solvents presently studied is measured to be  $\Phi_f = 0.26 \pm 0.03$ . The same fluorescence yield is obtained when calculated as a fraction of absorbed photons at low laser intensities or as a fraction of excited radicals (measured from the bleaching of the ground state) at saturation, as long as the amount of photochemical products is negligible.

Although the conclusion above that the photochemical product is present in the AcN solutions immediately at the end of the laser flash renders the possible reaction of an excited state with the parent carbinol rather unlikely, we studied the effect of initial concentration of DBHP-OH on the photochemistry. In the range of  $(0.5\text{--}5) \times 10^{-3} \text{ M}$  and constant laser intensity, no effect could be observed on the fraction of absorption decaying by the fast process at 410 nm ( $f_A = 0.50 \pm 0.04$ , e.g., Figure 9E). The rate of decay of the fluorescence, however, did increase somewhat at the higher concentration of the parent molecule. The dependence on the carbinol concentration yields  $k_q = 2 \times 10^8 \text{ M}^{-1} \text{ s}^{-1}$  for this quenching reaction. Nevertheless, since this reaction does not result in the species absorbing at 410 nm, no further investigations of this process were carried out.

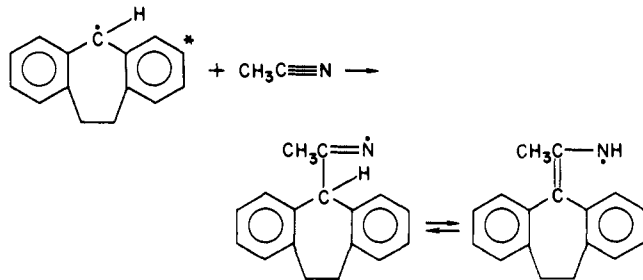
Among the radicals discussed in the present study, only DBHP• radicals may homolytically dissociate to yield *o*-xylylenes upon excitation. The latter is a well-known reaction, and the *o*-xylylenes have been observed to absorb light in the region of 400 nm.<sup>19</sup>





**Figure 12.** Summary of photophysical and photochemical processes of arylmethyl radicals observed in this study.

However, we would expect this reaction, if it occurs, to be observed in CHX as well. Since such is not the case, either the carbene rapidly reacts with CHX (or with its own H· counter radical) to regenerate the ground-state radical and not with AcN or the reaction in AcN involves the solvent. The absorption spectrum of the product of this reaction, peaking at 410 nm, is also similar to an anilino-type radical. The latter is known to absorb in this region.<sup>20</sup> A possible route to such a product is shown in the following reaction:



However, in view of the similarity in the photochemical behavior of DBHP· to Ph<sub>2</sub>CH·, and in view of the fact that for the latter radical, no product absorption at 410 nm is obtained, we favor the homolytic bond dissociation mechanism. We shall return to this point in the next section.

#### Photochemistry vs. Photophysics of Phenylmethyl Radicals.

Before proceeding with a comparative discussion of the events following excitation of the radicals presently studied, it might be helpful to summarize the observations reported above. Table I and Figure 12 summarize our main observations. It should be noted that the laser light excites the radicals into the edge of their so-called "near-UV band" which corresponds to their third excited state.

The radicals presently studied may be grouped into those exhibiting practically no photochemistry from the first excited doublet state (D<sub>1</sub>) and those exhibiting high quantum yield for photochemistry from D<sub>1</sub>. The first group would thus include Ph<sub>2</sub>CH· and DBHP· and the second group includes Ph<sub>2</sub>CCH<sub>3</sub>·, Ph<sub>2</sub>C·-c-Pr, and Ph<sub>3</sub>C·. Our suggestion that the second group exhibits photochemistry from D<sub>1</sub>, rather than from higher states, arises from the observation that the absorption spectrum of the product of this photochemical reaction is very different from that of the photochemical product of the first group. Furthermore, the photochemistry of the first group is a biphotonic process and

is very solvent dependent, while that of the second one is monophotonic and is solvent independent. There is little doubt that for the first group (Ph<sub>2</sub>CH· and DBHP·) the photochemistry does not arise from vibrationally relaxed D<sub>1</sub>.

The question of the differences in the reactivities of D<sub>1</sub> in the two groups may be addressed now. The absorption spectra of the ground states of all the radicals under consideration are quite similar (yet not identical). This indicates that all of them are excited by the laser light to D<sub>3</sub> (Figure 12). Studies of the quantum yield for fluorescence of Ph<sub>3</sub>C· at low temperatures<sup>21</sup> indicate higher fluorescence quantum yields for the latter than for Ph<sub>2</sub>CH·. Thus, the radiative lifetime for D<sub>1</sub> of Ph<sub>3</sub>C· is considerably shorter than for Ph<sub>2</sub>CH·, while the nonradiative lifetimes for both are quite similar. Nevertheless, at room temperature, D<sub>1</sub> for Ph<sub>3</sub>C· is much more reactive. A probable rationalization for this observation may arise from the differences in the geometries of the radicals of the two groups represented by Ph<sub>3</sub>C· and Ph<sub>2</sub>CH·. The propeller-like configuration of diarylmethyl compounds caused by the steric crowding of the ortho hydrogens in an effort to achieve coplanarity of the π system of the phenyl rings has been verified and tested extensively.<sup>22,23</sup> Estimates obtained from X-ray diffraction, EPR studies, and MO calculations yield 30°–40° for the twist angle of the phenyl rings. Although most of these estimates are not sensitive to small changes in the twist angle, it is quite clear that this angle is smaller in Ph<sub>2</sub>CH· than in Ph<sub>3</sub>C· or Ph<sub>2</sub>CCH<sub>3</sub>· radicals. For the closely related diphenylethyl anion, geometry optimization yields as much as a 90° twist of one phenyl ring relative to the other. DBHP· radicals will have a similar or even smaller twist angle than Ph<sub>2</sub>CH·. The experimental results described above suggest a correlation between the twist angle and reactivity of the D<sub>1</sub> state. An increase in this angle leads to increased reactivity while increased coplanarity of the phenyl rings minimizes this reactivity. This correlation is to be expected if the hypothesis of photocyclization holds. Formation of a new carbon-carbon σ bond out of the two corresponding p orbitals of the carbon atoms will require a perpendicular configuration of the two phenyl rings relative to one another in the transition state. Stabilization of the resultant cyclic radical into a planar configuration will occur at a latter stage.

The solvent-dependent photochemical reactions of states higher than D<sub>1</sub> (i.e., of Ph<sub>2</sub>CH· and DBHP·) are a result of consecutive biphotonic excitation. The general similarity in the results obtained in a variety of solvents and the similarity of the Ph<sub>2</sub>CH· to DBHP· radicals suggest a photochemical biphotonic process common to all solvents and to the two radicals. We, therefore, hypothesize that both radicals may undergo a homolytic bond cleavage upon further excitation of the lowest excited state. Most probably such a bond scission will occur at the central carbon to yield a hydrogen atom-carbene pair. Either this pair can recombine or the carbene may abstract hydrogen from the solvent<sup>24</sup> (Ph<sub>2</sub>CH· and DBHP· in CHX) to yield back the parent radical in its ground state. However, in alcohols the carbene moiety obtained from both radicals would rapidly react to yield the insertion products. For the carbene obtained from DBHP· in AcN, transformation into *o*-xylylene is possible and has been recently invoked.<sup>25</sup> Since no photochemical product absorbing at 410 nm is observed for Ph<sub>2</sub>CH·, we favor the *o*-xylylene product over an addition product to AcN. Our effort to propose a unified, most simple mechanism also requires bond cleavage at the central carbon atom in both radicals rather than primary bond cleavage at the *o*-methylene position in DBHP·. We may also note that the photochemical reaction presently observed with alcohols resembles that of singlet or excited triplet states of diphenyl carbene.<sup>26</sup> This hypothesis,

(21) Bromberg, A.; Meisel, D., unpublished results.

(22) (a) Hoffmann, R.; Bissell, R.; Farnum, D. G. *J. Phys. Chem.* **1969**, *73*, 1789. (b) Andersen, P.; Klewe, B. *Acta Chem. Scand.* **1967**, *21*, 2599. (c) Andersen, P. *ibid.* **1965**, *19*, 629. (d) Liebman, S. A.; Dalton, D. R.; Knudsen, T.; Underwood, G. *J. Magn. Reson.* **1973**, *10*, 85. (e) Schreiner, K.; Berndt, A.; Baer, F. *Mol. Phys.* **1973**, *26*, 929.

(23) Adams, S. M.; Bank, S. *J. Comput. Chem.* **1983**, *4*, 470.

(24) Closs, G. L.; Rabinow, B. E. *J. Am. Chem. Soc.* **1976**, *98*, 8190.

(25) Hadel, L. M.; Platz, M. S.; Wright, B. B.; Scaiano, J. C. *Chem. Phys. Lett.* **1984**, *105*, 539.

(19) Migirdicyan, E.; Baudet, J. *J. Am. Chem. Soc.* **1975**, *97*, 7400.

(20) Land, E. J.; Porter, G. *Trans. Faraday Soc.* **1963**, *59*, 2027.



which seems to account for all the experimental observations, is summarized in Figure 12. It should, however, be realized that the scheme presented in Figure 12 is still largely phenomenological. Structure-photoreactivity correlations of the excited states are yet to be unraveled, and the role of the quartet manifold, if any, in the photochemical pathways of the higher excited states is completely unknown.

Finally, the ability to monitor the absorption spectrum of  $D_1$  could allow some significant observations on the energy levels of the radicals. In principle, due to parity selection rules, transitions which are forbidden for the ground state have to become symmetry-allowed in the first excited state. In the radicals for which

(26) Sitzmann, E. V.; Wang, Y.; Eisenthal, K. B. *J. Phys. Chem.* **1983**, *87*, 2283.

the absorption spectra of  $D_1$  were monitored, the lowest observable transition corresponds to excitation to a level which lies 5.3 eV above the ground state. Since neither experimental nor calculated information is available on the absorption spectrum of the ground state in this region, comparison at this stage between the absorption spectra of the two states is premature.

**Acknowledgment.** The dedicated operation of the linac by D. Ficht and G. Cox is gratefully acknowledged, as is the technical assistance of P. Walsh and R. Clarke.

**Registry No.** DBHP-OH, 1210-34-0; DBHP-Cl, 1210-33-9; DBHP, 93564-50-2;  $\text{Ph}_2\text{CHCl}$ , 90-99-3;  $\text{Ph}_2\text{CHOH}$ , 91-01-0;  $\text{Ph}_2\text{C}(\text{CH}_3)\text{OH}$ , 599-67-7;  $\text{Ph}_3\text{CCl}$ , 76-83-5;  $\text{Ph}_3\text{COH}$ , 76-84-6; (c-Pr)CPh<sub>2</sub>, 17787-94-9;  $\text{Ph}_3\text{CH}$ , 4471-17-4;  $\text{Ph}_3\text{C}^+$ , 2216-49-1;  $\text{Ph}_2\text{CCH}_3$ , 51314-23-9;  $\text{CH}_3\text{C}\equiv\text{N}$ , 75-05-8;  $\text{Ph}_2\text{C}(\text{c-Pr})\text{OH}$ , 5785-66-0; 1-(10,11-dihydro-5H-dibenzo[a,d]cyclohepten-5-ylidene)ethyl amidogen, 93474-28-3.

## Problems of CD Spectrometers. 3. Critical Comments on Liquid Crystal Induced Circular Dichroism

Yohji Shindo\* and Yasuhiro Ohmi

Contribution from the Research Institute for Material Science and Engineering, Faculty of Engineering, Fukui University, Fukui 910, Japan. Received June 15, 1984

**Abstract:** The Mueller matrix approach is used to analyze the apparent circular dichroism (CD) spectra observed in cholesteric liquid crystals (CLC) which can be regarded as being built up of a large number of thin birefringent layers arranged helically. Attention is called to the artifacts resulting from coupling of CLC with nonideal optics and electronics of the CD spectropolarimeter. On the basis of the results obtained, it is concluded that "liquid crystal induced CD" cannot be related to true optical activity without careful consideration of the experiment.

More than 100 papers have been published since the first report on liquid crystal induced circular dichroism (LCICD) in 1971<sup>1</sup> and the number of papers is still increasing. Norden<sup>2,3</sup> and Jensen<sup>4</sup> called attention to the instrumental limitation of CD spectrometers in studying CD phenomena of liquid crystals and other systems with macroscopic anisotropy. They also demonstrated the usefulness of the Mueller matrix algebra for analyzing the data obtained. But their very important papers are frequently ignored, and LCICD spectra measured with commercial CD spectropolarimeters have been widely accepted as representing an induced optical activity of achiral molecules dissolved in cholesteric liquid crystals without any doubt. Is this really true? Our answer is "no", and the very reason for this is presented in this paper.

A paper by Tunis-Schneider et al.<sup>5</sup> has been used for the theoretical support of LCICD. But this work has the serious limitation of assuming that the CD spectrometer is ideal. In practice, however, there is no ideal CD spectrometer, whether it is commercially built or homemade. In our first paper of this series,<sup>6</sup> we show that a modern CD spectrometer is fundamentally a polarization-modulation spectrometer with the systematic errors inevitable in polarization-modulation techniques due to a partially polarizing detector, residual static strain birefringence of the

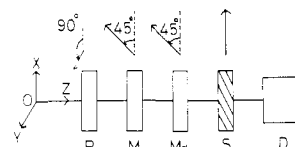


Figure 1. Optical arrangements showing the orientation of the optical components: P, polarizer; M, PEM;  $M_s$ , residual static strain retardation of PEM; S, sample; D, photomultiplier.

electrooptical modulator, and a first harmonic response of a lock-in amplifier. Even in an ideal CD spectrometer, their discussion is valid only under the very restricted condition that linear dichroism (LD) and linear birefringence (LB) of the sample are small. But the linear effects of liquid crystals are, in reality, by no means small. In the previous paper,<sup>7</sup> we considered the artifacts resulting from the coupling of an anisotropic medium and nonideal optics and electronics of the CD spectrometer. Therefore, the method of analyzing apparent CD data proposed by Tunis-Schneider et al. can in practice never be applied to liquid crystals and other systems with macroscopic anisotropy.

In this paper, we focus our attention to the apparent CD signals observed in cholesteric liquid crystals which can be regarded as being built up of a large number of helically arranged thin birefringent layers. We investigate this problem by using the same Mueller matrix approach as described in our earlier papers. Our conclusion is that a LCICD spectra measured with commercially available CD spectrometers cannot generally be used as proof of optical

(1) Saeva, F. D.; Wysocki, J. J. *J. Am. Chem. Soc.* **1971**, *93*, 5928-5929.  
 (2) Norden, B. *J. Phys. Chem.* **1977**, *81*, 151-159.  
 (3) Davidsson, A.; Norden, B.; Seth, S. *Chem. Phys. Lett.* **1980**, 313-316.  
 (4) Jensen, H. P.; Schellman, J. A.; Troxell, T. *Appl. Spectrosc.* **1978**, *32*, 192-200.  
 (5) Tunis-Schneider, M. J. B.; Maester, M. F. *J. Mol. Biol.* **1970**, *52*, 521-541.  
 (6) Shindo, Y.; Nakagawa, M., *Rev. Sci. Instrum.*, in press.

(7) Shindo, Y.; Nakagawa, M. *J. Appl. Spectrosc.*, in press.